

7th International Symposium on Liquid Metals Applications for Fusion. ISLA-7. Chubu U. Japan. 12-2022



Studies of Thermal Sputtering and Vapor Shielding of Sn in the OLMAT HHF Facility

Francisco L. Tabarés and the OLMAT Team
CIEMAT. Madrid. Spain.



This work has been carried out within the framework of the EUROfusion Consortium and has received funding from the European Union's Horizon 2020 research and innovation programme under grant agreement number 633053. The views and opinions expressed herein do not necessarily reflect those of the European Commission.

OUTLOOK



- Motivation
- Plasma Characterization.
- Thermal Sputtering of Sn
- Vapor Shielding effects
- Conclusions.

Why these studies



- Liquid Metals are a reasonable alternative to solid targets for a fusion reactor (*lack of permanent damage, in situ refilling, tritium extraction, etc...*)
- They have some peculiarities *wrt* impurity generation:
 - 1) Droplet ejection (- -) **CPS solution?**
 - 2) Thermal (enhanced) Sputtering (-)
 - 3) Vapor Shielding effects (+)+missing AM data for diagnostics/modeling: CRP launched by IAEA
- **Studies in OLMAT (de Castro presentation):**
 - 1) Optimization of CPS geometry (Oyarzabal presentation)
 - 2) Thermal sputtering
 - 3) Vapor Shielding
 - 4) Generation of a AM data base for LM's (?)

Contribution of Sn vapor shielding studies to the IAEA CRP on VS



- Sn outstands as first LM candidate for DEMO divertor (recently tested in AUG)
- Compared to Li, Sn is far less studied (AM database)
- Thermal sputtering may be the main contributor to impurity fluxes in LM-based divertor targets
- In cold divertors, high Z Impurities are mostly generated by keV ion sputtering during ELMS (JET, AUG, 20keV in ITER?..)
- Vapor shielding effect for Sn seen in Pilot PSI at 2000K
- OLMAT offers reproducible conditions at high powers (up to 60MW/m^2) Suitable for AM studies thanks to local plasma characterization.

The OLMAT HHF Facility

OLMAT : Optimization of Liquid Metal Advanced Targets

Alternate use of TJ-II Neutral Beam Injectors for material irradiation in a test bed and for plasma heating in a magnetized fusion device.

Project deployed in three phases

Phase 1) NBI exposure of LM prototypes. Comparative studies (<150ms pulses, no ELMs)

✓ **Phase 2) Addition of ELM-like loads (Laser pulses)**

Phase 3) Long NBI pulse (up to 5 s)+ ELMs

$E_{\text{beam}} < 32\text{kV}$ (3 components, $E_0, 1/2$ and $1/3$)
 $W < 705\text{ kW}$ ($60\text{MW}/\text{m}^2$) $\Gamma < 1,5 \cdot 10^{22}\text{ m}^{-2} \cdot \text{s}^{-1}$

Operation start-up: April 2021

- Liquid Sn and several CPS structures tested
- Also used for ITER amour material tests (TZM, W).

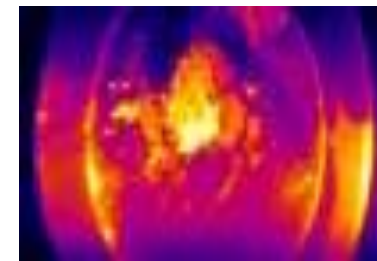
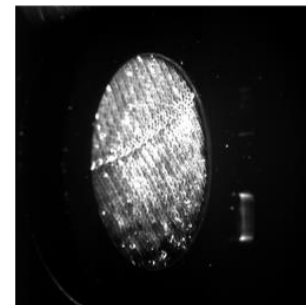

Diagnosics

TJII

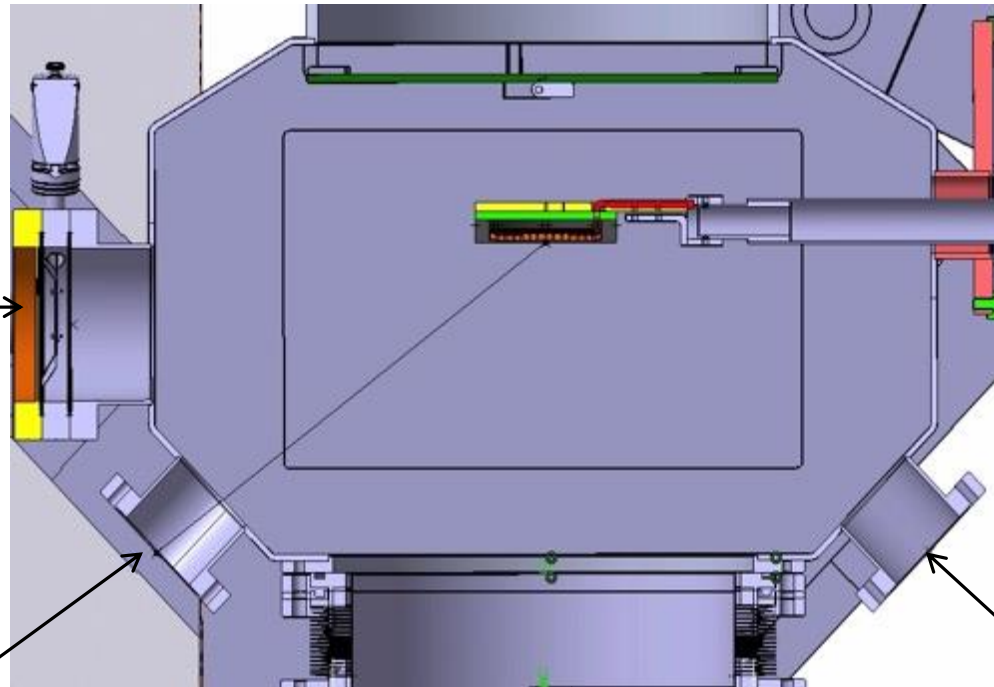

Mirror

16-channel photomultiplier array
Sn, Halfa filter

Fast camera (new)
Sn, Halfa filter

+ Laser 9kW pulsed

NBI

IR camera

Thermocouples
Vfloating and Isat.
+Lang. Probes in TZM!!

Pyrometers
CMOS-based spectrometer
Spectra from 236 to 812 nm.

Electric Characteristics in TZM target



- Preliminary results. **Only in TZM target.**

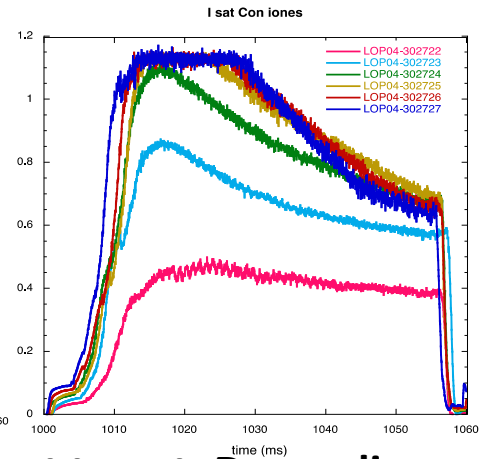
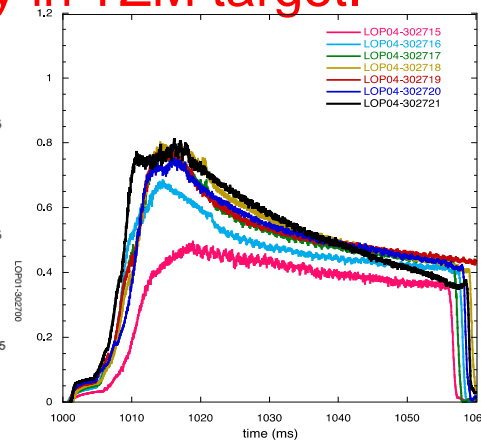
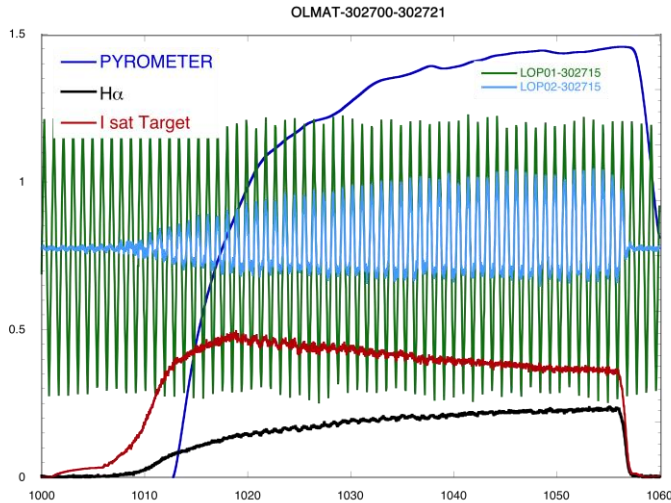

I sat, V float target: Depending on power and ion contribution

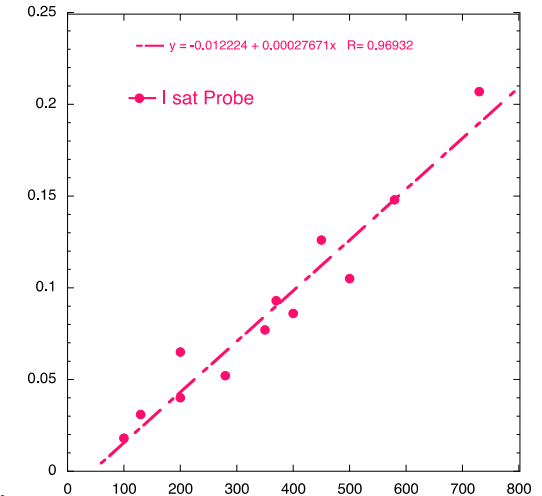
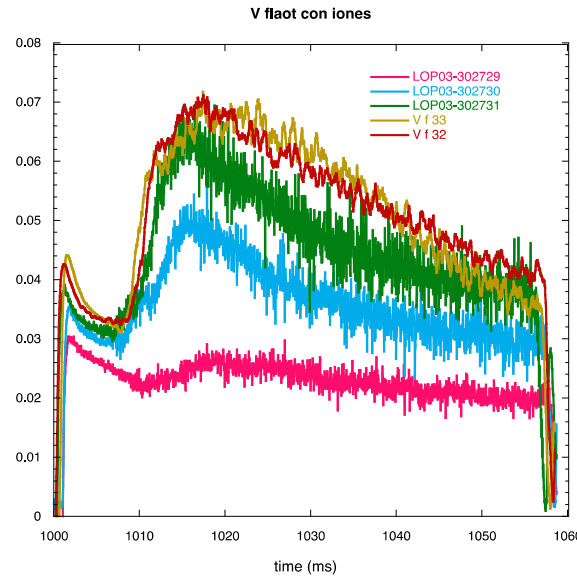
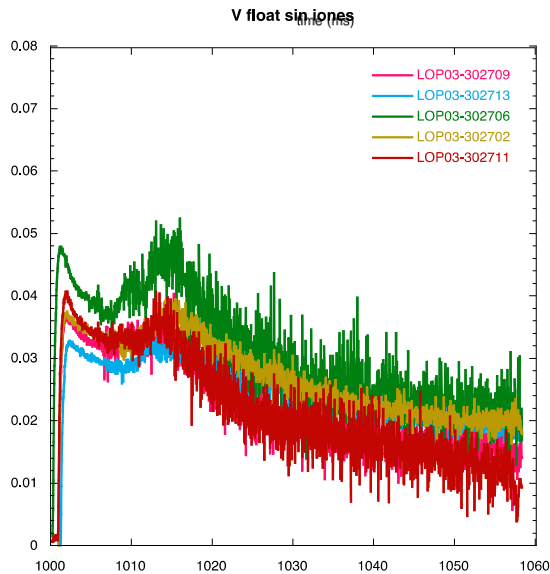

But: I_{sat} probe \sim power

Plasma parameters. Spectroscopy



A plasma is generated by the interaction of High Energy H atoms and target.

- How? : $H_{hot} + H_2 \rightarrow H_2^{++} + e^-$, SEE by high E_{ptcl} impact on metals >1, others?.
- Clear dependence of plasma parameters on target material (work function, recycling?).

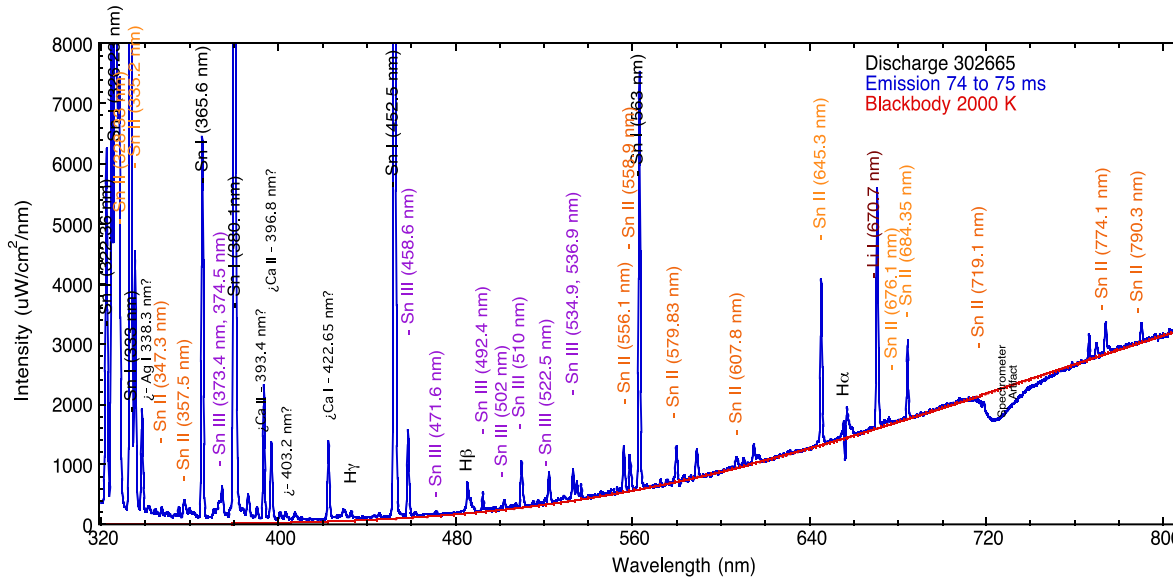
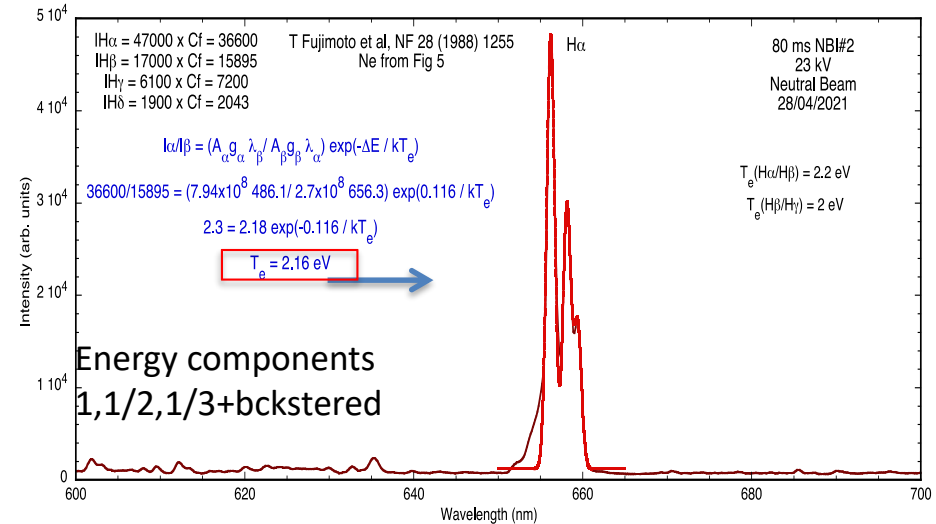

- SnI, II and III lines detected
- Weak H emission lines
- Ratio SnI/SnII, $T_e=1.5$ eV
- Black Body spectrum: T_{sample}

Generation of a pure Sn plasma?

Emission profiles



Fast camera from perpendicular LOS. Sn filter @ 452 nm.

Reflexion?

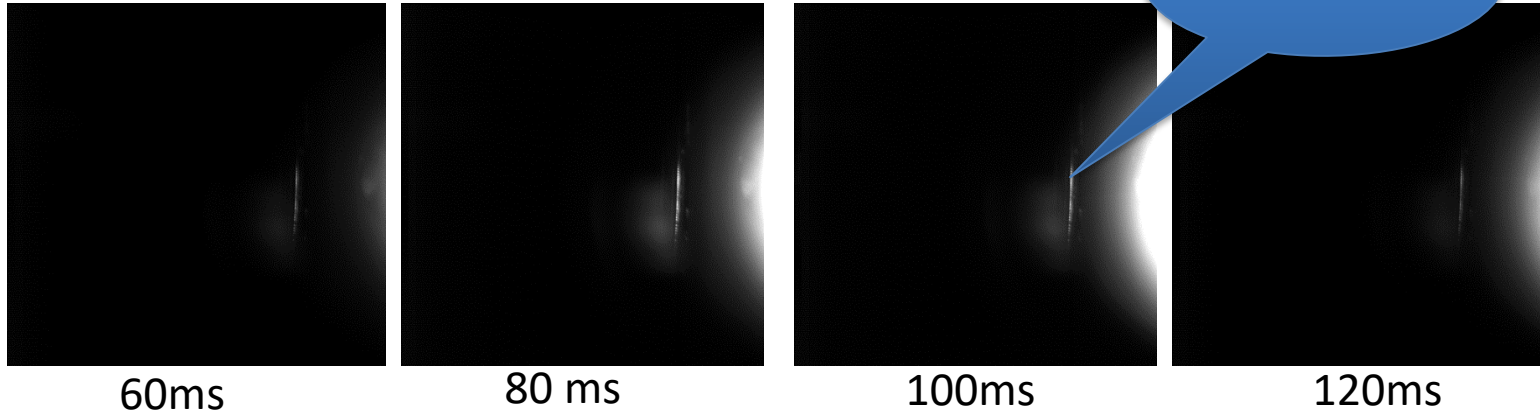

PM Array: 1ch=0.35cm

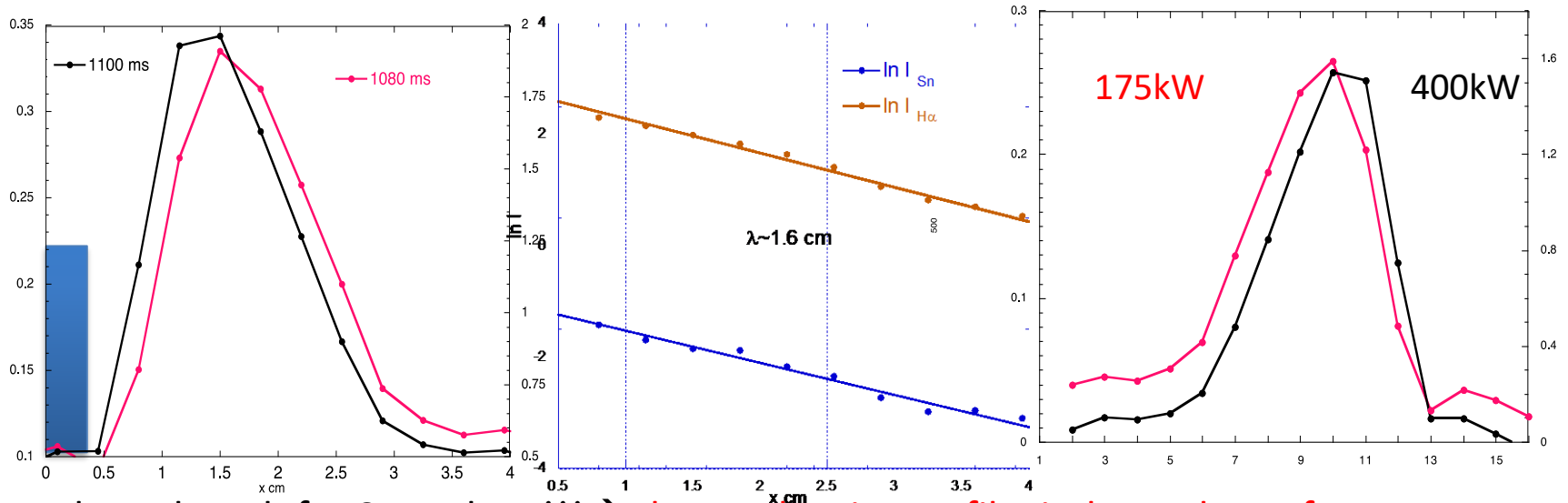

Same decay length for Sn and H α !!! \rightarrow Plasma density profile, independent of Power

Studies of thermal sputtering of Sn



T Abrams, FED 2014

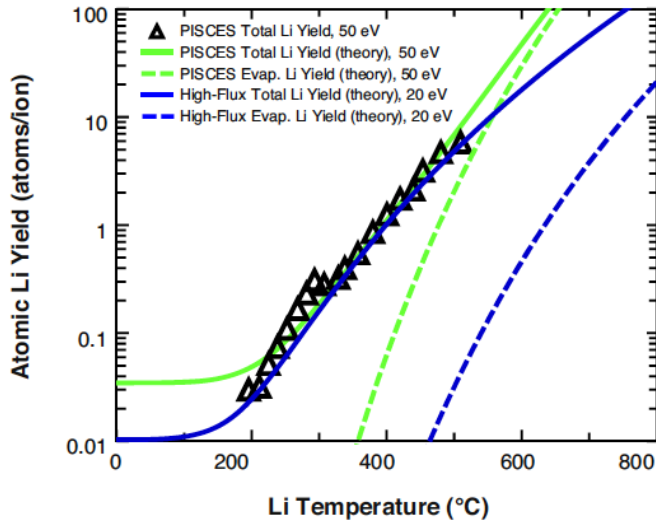
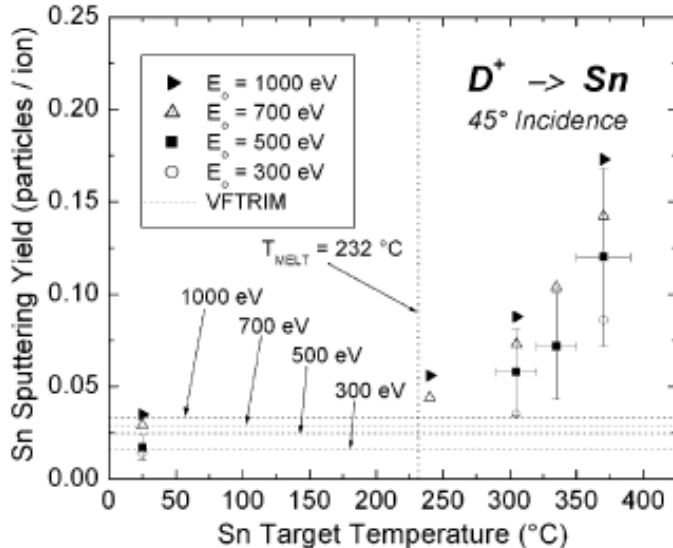

Fig. 2. Plot of the evaporative and total atomic Li yields vs. Li temperature for the plasma conditions presented in [18] ($50 \text{ eV}, 8 \times 10^{21} \text{ m}^{-2} \text{ s}^{-1}$) as well as a high-flux, low-energy case ($20 \text{ eV}, 5 \times 10^{23} \text{ m}^{-2} \text{ s}^{-1}$) using Eq. (4).

Coventry et al. JNM (2004)



Adatom model:

$$Y_{\text{thermal}}(T_{\text{surf}}) = \frac{A}{\sqrt{k(T_{\text{surf}} + B)}} \exp \left[-\frac{U}{k(T_{\text{surf}} + B)} \right]$$

$A=0.016, B=350 \text{ }^\circ\text{C}$ for Li

$$\text{Flux}_{\text{Sn}} = F_{\text{H}}^* (\gamma_{\text{Sputt}} + \gamma_{\text{Ther Sputter}}) + F_{\text{Evap}}$$

Also postulated for Sn. **No parameters available**

Morgan et al JNM 2015

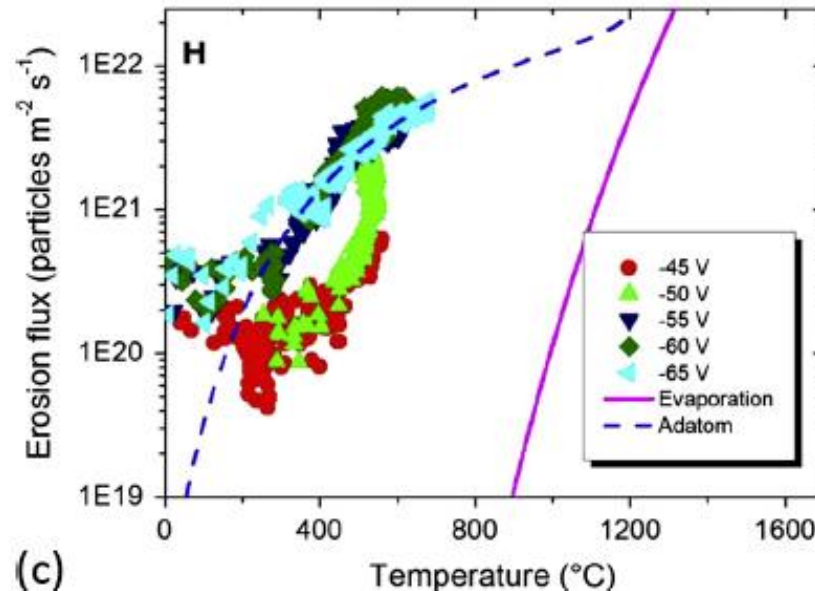

Checking for model consistency



- At $T \ll T_{\text{evap}}$, $\text{Flux}_{\text{Sn}} \propto \text{Flux}_{\text{H}} \text{ (beam) @ } T \text{ fixed}$

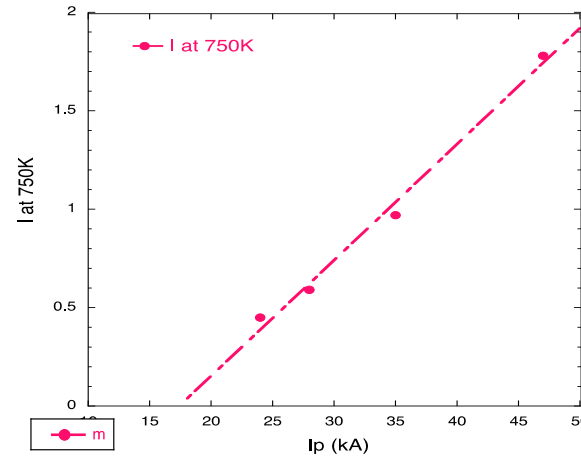
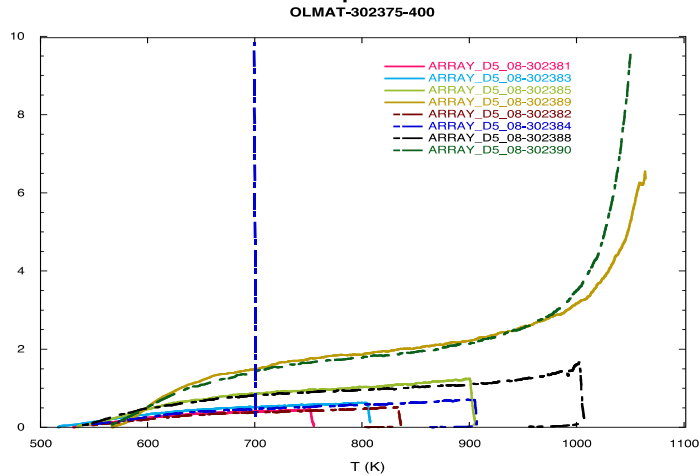

Constant excitation
Rate of Sn btwn
150-350kW

- Slope of ΔT vs $\sqrt{t} \propto Q \text{ (MW/m}^2 \text{) (slab model)}$

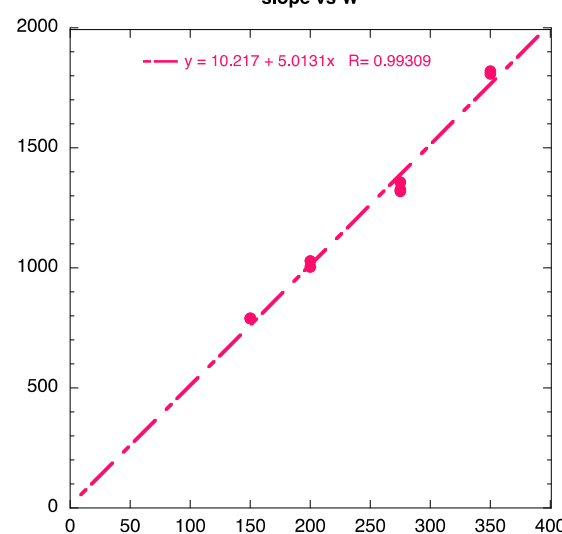
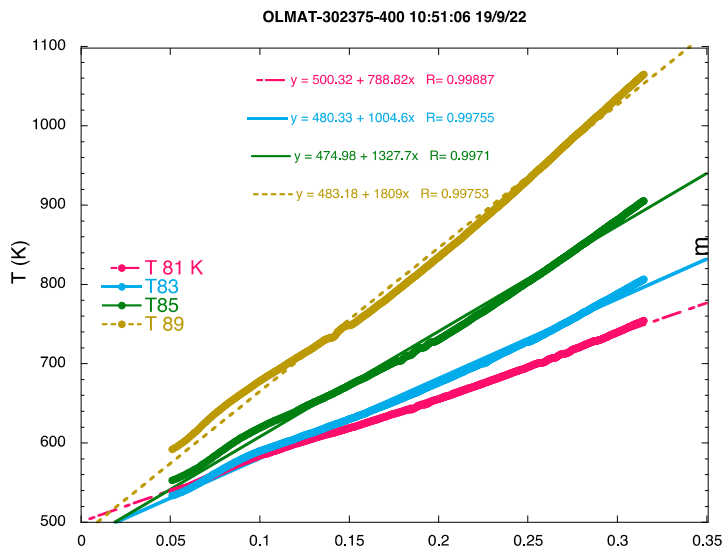

Good fitting to Slab model
Constant thermal
Parameters (C_p , ρ , κ)

Fitting to adatom expression

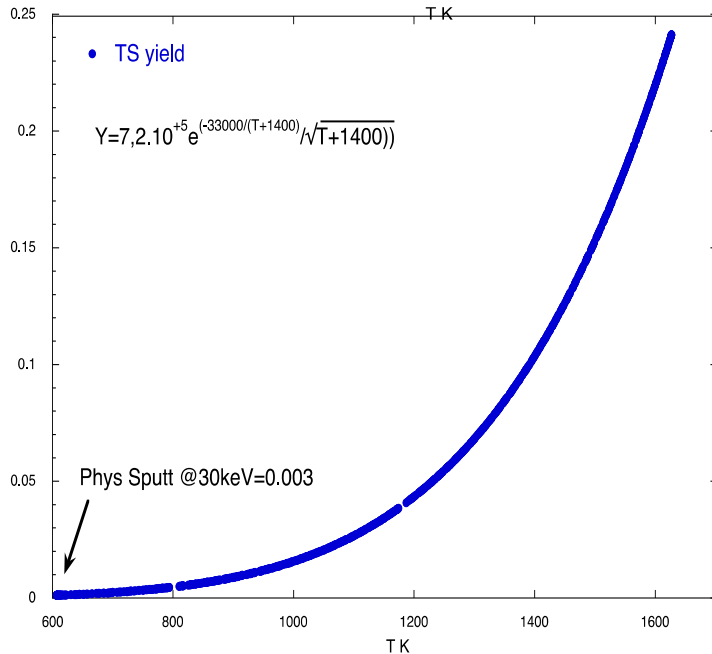
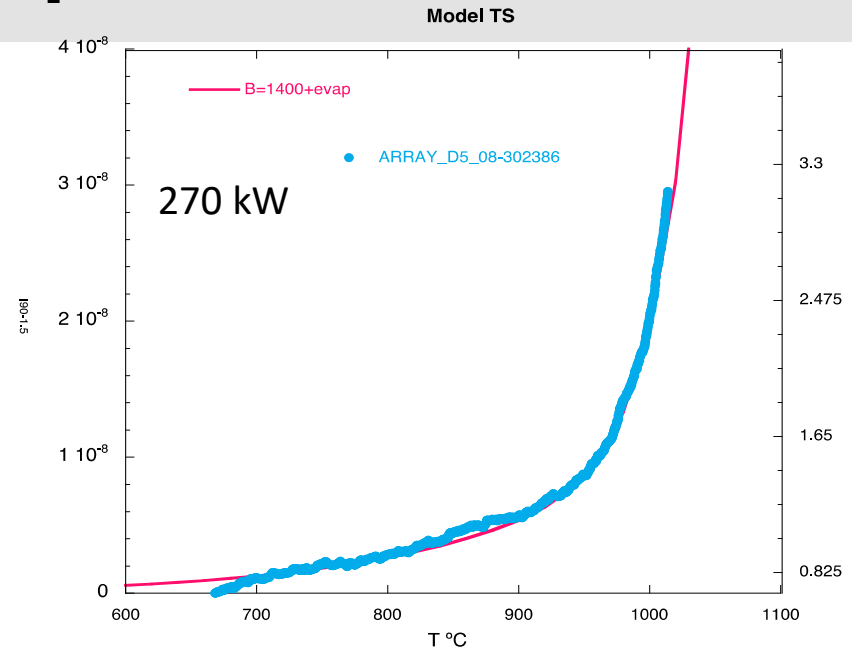
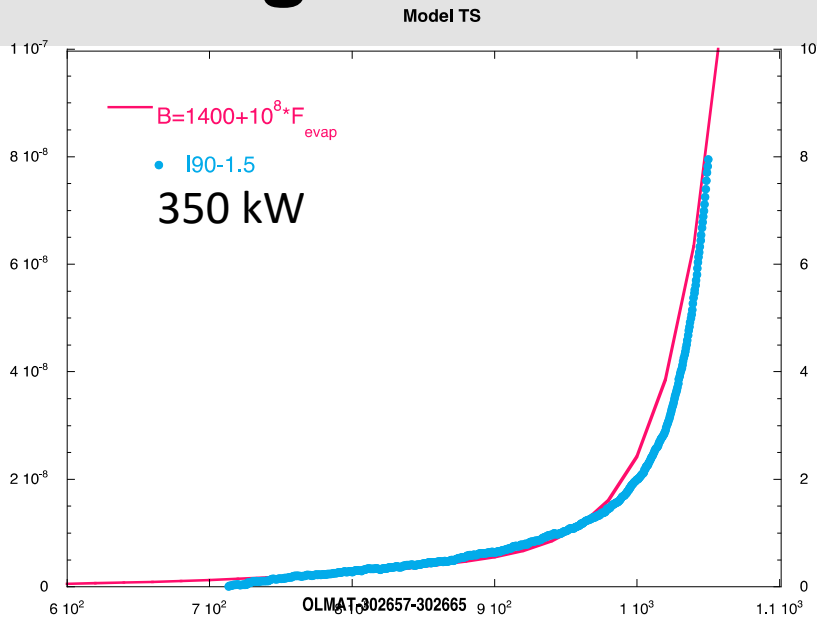

Sputt yield: $\gamma=7.2 \cdot 10^5 \exp(-33000/(T+1400)) / \sqrt{T+1400}$

For Li: $\gamma=4.3 \cdot 10^9 \exp(-18400/(T+350)) / \sqrt{T+350}$

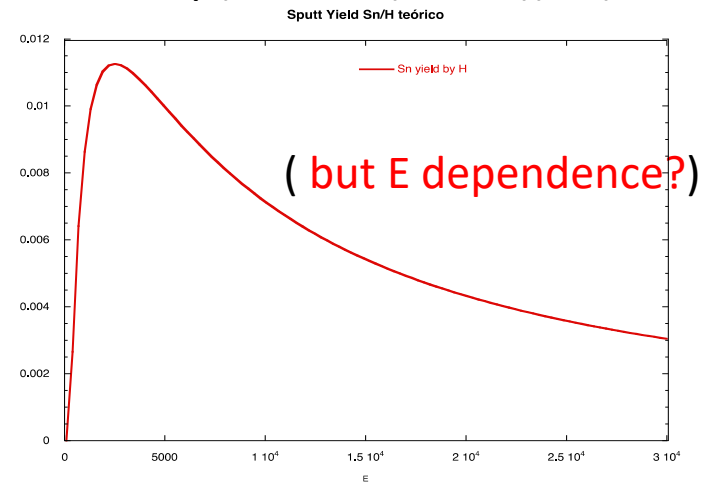

High Power/High T



OLMAT-302657-302665

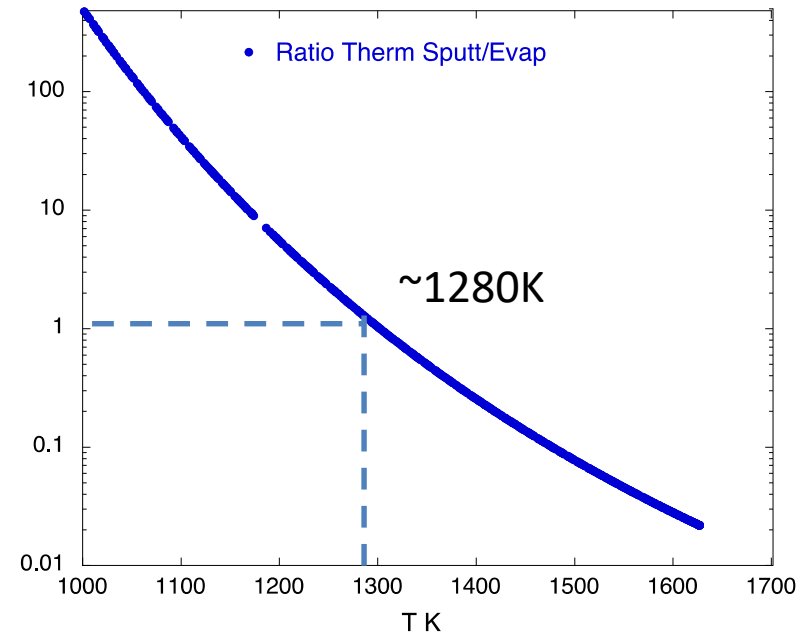
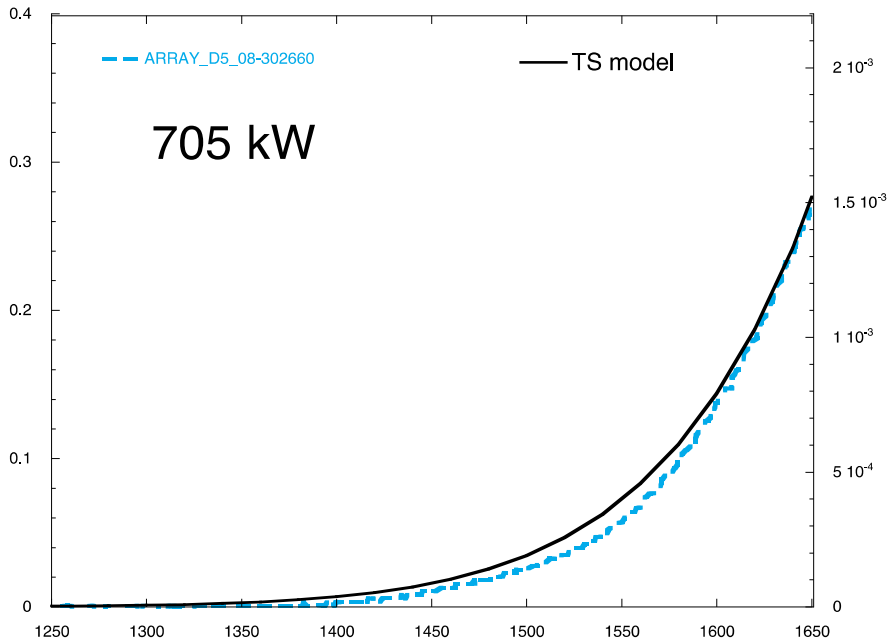

At maximum power (high T), fitting with evaporation only OK!!
At $T > 1300\text{K}$, evaporation dominates

Vapor Shielding



- For short pulses, no T clamping to be expected
- But..deviation from slab model?

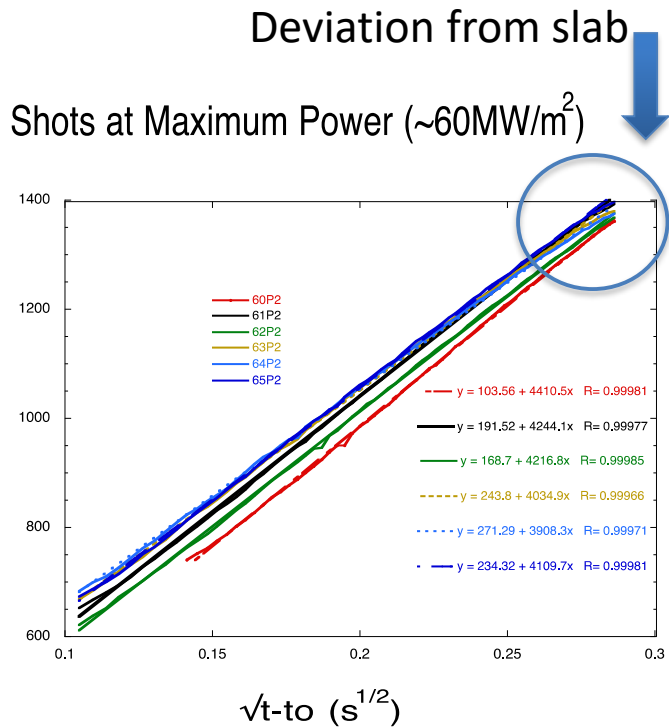

BUT: Window coating?

Repetitive discharges with retracted observation window at max V

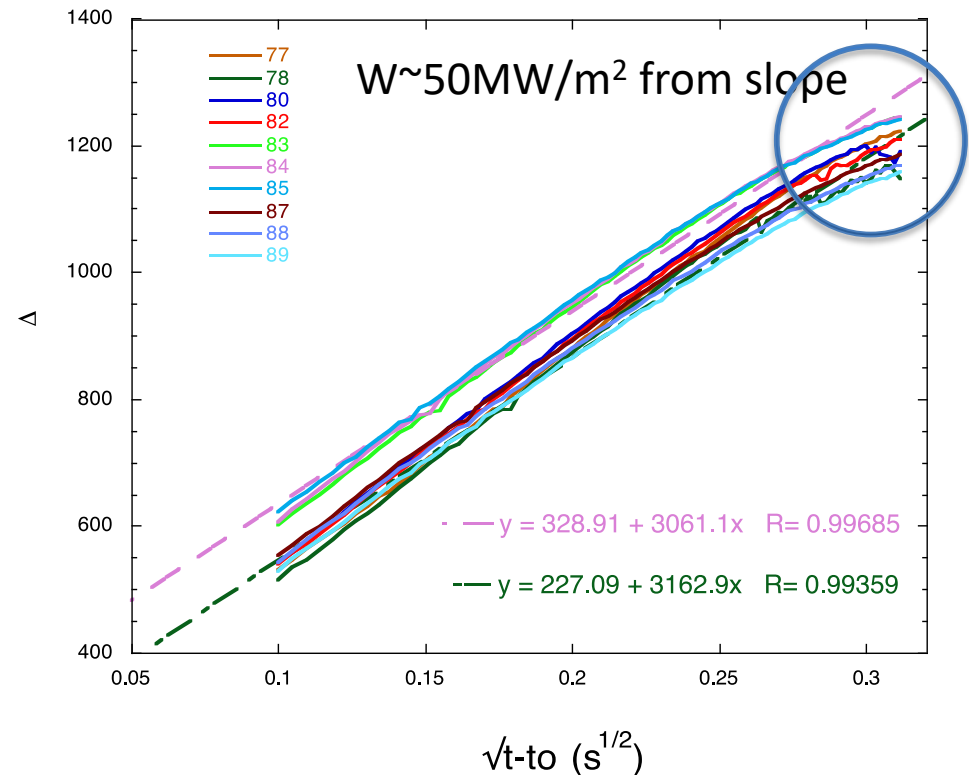

Vapor Shielding: Parametric dependence

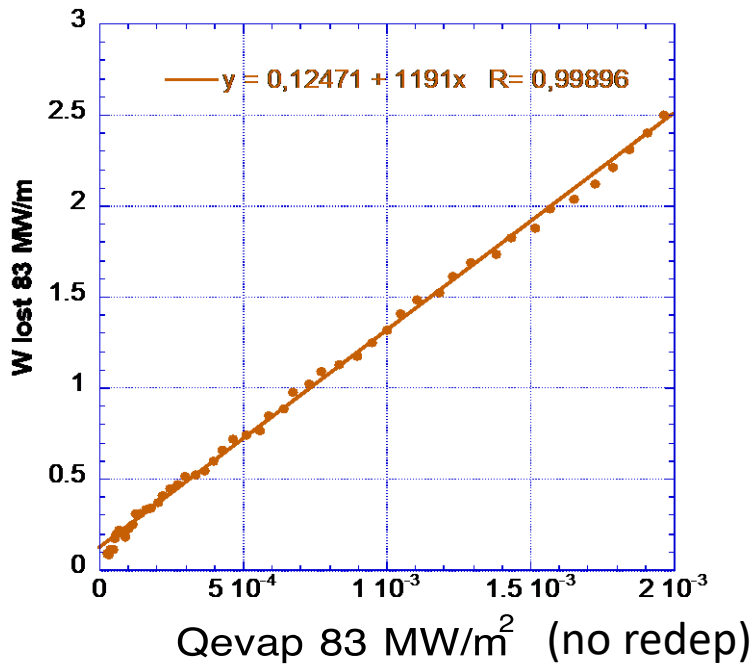

Dispersion of slope → Te variations?

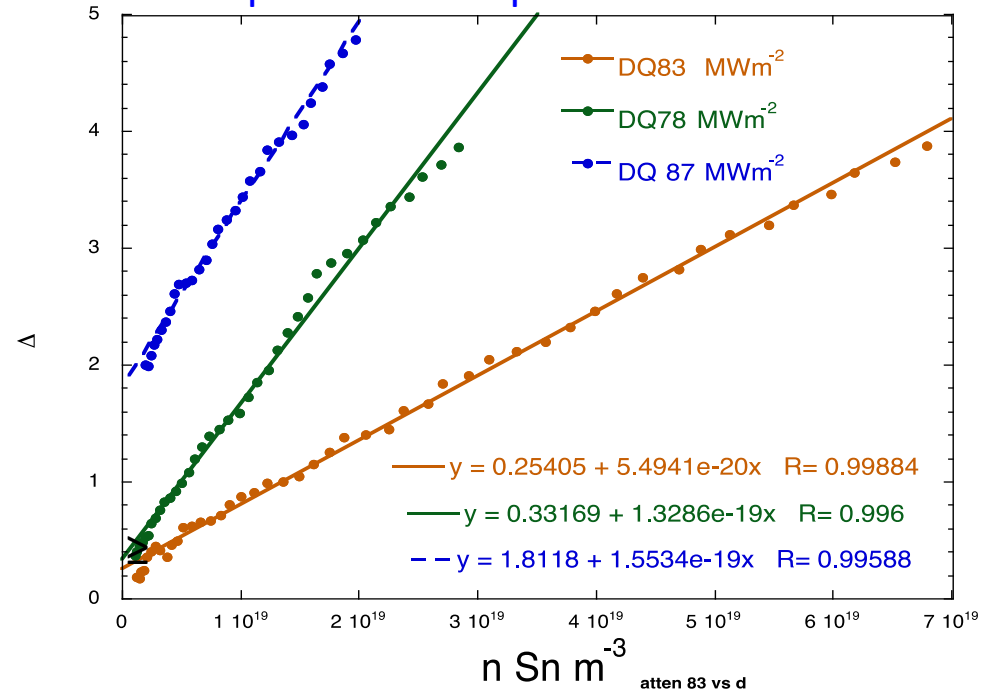

• $Q_{rad} \sim L_z \cdot n_e \cdot n_z$

From slopes, at $n_e = 5 \cdot 10^{18} \text{ m}^{-3}$ and $\delta = 2.5 \text{ cm}$

$L_z > 4 \cdot 10^{-31} \text{ W/m}^3$

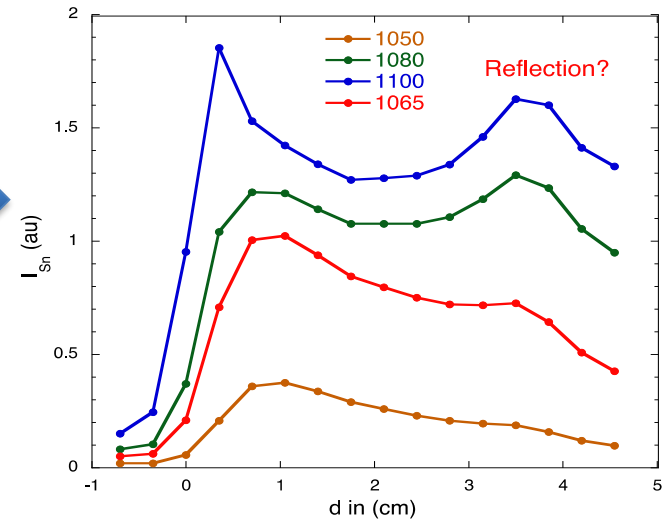

Analysis of Results

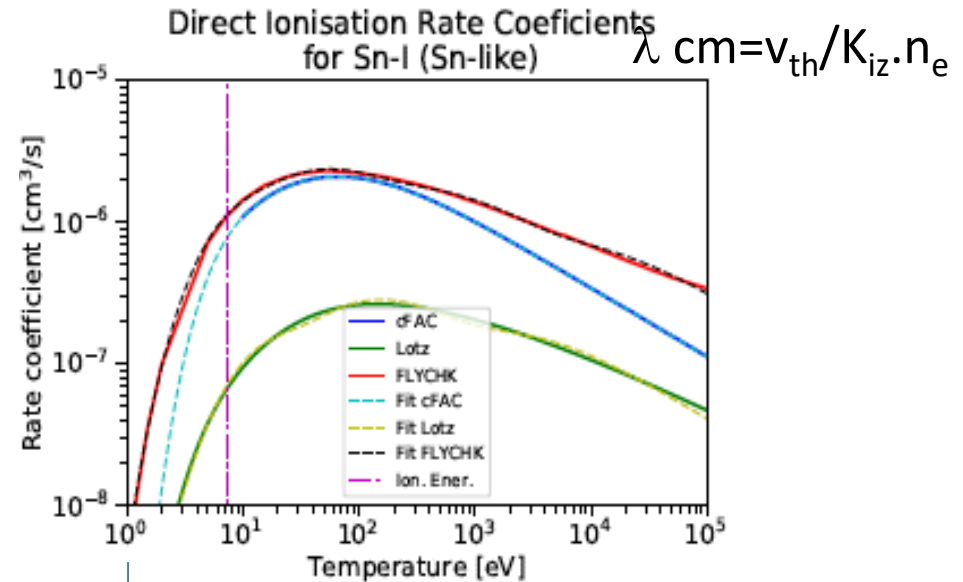
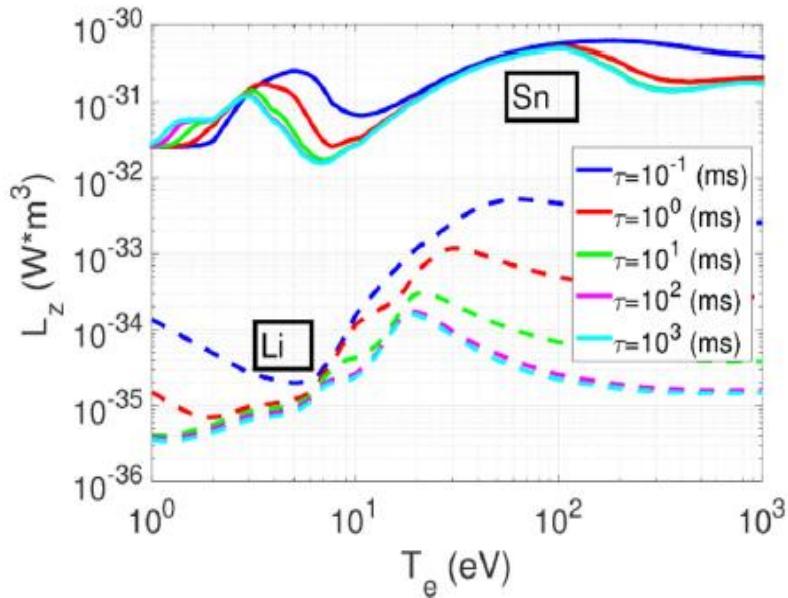

From Putterich et al. 42nd EPS Lisbon 2015

If Sn attenuated in ablation plasma

$$K_{iz} \sim 3 \cdot 10^{-9} \text{ cm}^3/\text{s} @ 2-3 \text{ eV.}$$

Warning!!: What will be the composition of local plasma
At $n_{\text{Sn}} \gg n_{\text{D}}/T$?: pure Sn plasma?? → Enhanced Radiation?

For DEMO: $F \sim 10^{24} \text{ m}^{-2}$, → $T > 1800 \text{ K}$

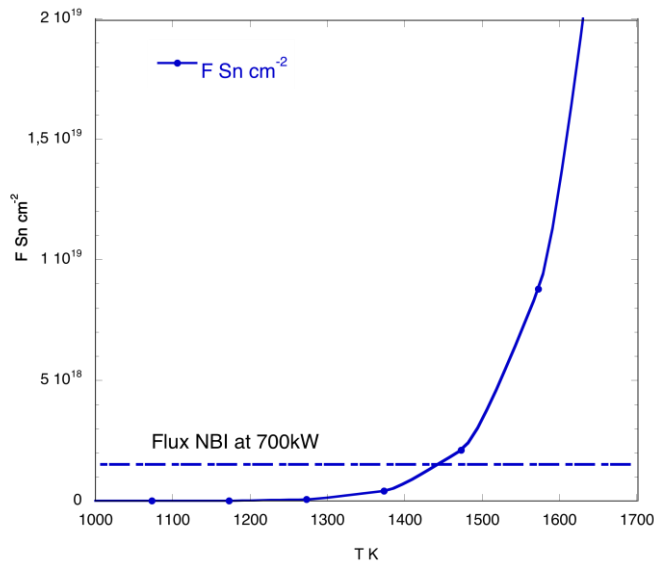

Conclusions



- The new HHF Facility for testing divertor material candidates for a Fusion Reactor, OLMAT, has been used to investigate elemental processes in LM exposed to very high powers. Target plasmas (plume) were characterized by OES and LPs
- Thermal sputtering of Sn by 30keV H beam was characterized in the range of $T=MP$ to 1700K. The functionality predicted by the adatom model was confirmed.
- Evaporation overrides sputtering at $T>1300K$ for the highest heat fluxes.
- The onset of Vapor Shielding was detected at $T\sim 1600K$
- **A linear dependence of dissipated power on Sn density was found beyond the heat of vaporization regime.**
- This regime corresponds to Sn evaporative fluxes equal or greater than NBI fluxes.
- The values deduced for Lz and K_{iz} Sn are in very good agreement with AM bibliographic data.
- A pure Sn plasma could be deployed at the divertor target under high T conditions, thus enhancing the VS effect.
- More experiments ongoing with the help of a high power fiber laser.

Conclusions



- The new HHF Facility for testing divertor material candidates for a Fusion Reactor, OLMAT, has been used to investigate elemental processes in LM exposed to very high powers. Target plasmas (plume) were characterized by OES and LPs
- Thermal sputtering of Sn by 30keV H beam was characterized in the range of $T=MP$ to 1700K. The functionality predicted by the adatom model was confirmed.
- Evaporation overrides sputtering at $T > 1300$ K for the highest heat fluxes.
- The onset of Vapor Shielding was detected at $T \sim 1600$ K
- **A linear dependence of dissipated power on Sn density was found beyond the heat of vaporization regime.**
- This regime corresponds to Sn evaporative fluxes equal or greater than NBI fluxes.
- The values deduced for L_z and K_{iz} Sn are in very good agreement with AM bibliographic data.
- A pure Sn plasma could be deployed at the divertor target under high T conditions, thus enhancing the VS effect.
- More experiments ongoing with the help of a high power fiber laser.